



Galaxy Casters & Glides, Inc.

* * * * *

1860 South Carlos Avenue, Ontario, CA 91761

Tel : (909) 927-7455 Fax : (951) 228-9193

Where are we located?

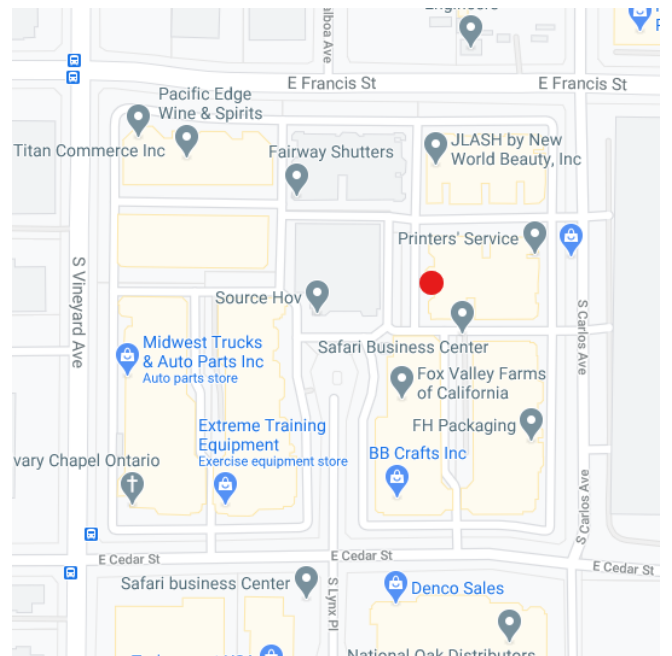



Casters & Glides, Inc.

Galaxy Casters & Glides, Inc.

* * * * *

1860 South Carlos Avenue, Ontario, CA 91761

Tel : (909) 927-7455 Fax : (951) 228-9193

GENERAL TERMS AND CONDITIONS OF SALE

- ~ Net 30 days (on approved credit).
- ~ Until credit has been established with our credit department, all accounts will be placed on **C.O.D.** Or **PREPAID** status.
- ~ To establish credit, please complete the Application for Credit form included on the following page.
- ~ Please allow 7 to 15 business days for credit approval.
- ~ **Order requirement:** one **(1)** Full **box** per item in quantity OR **\$75.00** in **Value/Invoice** excluding Shipping and Taxes. A surcharge of **\$ 15.00** will be added to any order which does not meet this requirement.
- ~ Some items may be ordered at **half a box quantity** but a **surcharge of 10%** will be applied for these items.
- ~ All goods are sold **F.O.B. Ontario**, California.
- ~ A finance charge of **1.5%** per month will be charged on all past due balances.
- ~ Any check returned / unpaid from the bank will be subject to a service charge of **\$15.00**.
- ~ No merchandise may be returned without prior authorization.
- ~ Returned goods are subject to a **15%** restocking charge.
- ~ Special orders are **Non-returnable**.
- ~ All claims for shortage or damage of shipped merchandise must be filed within **10 days** of receipt of such goods.
- ~ Our liability is limited to replacement of merchandise only.
- ~ No guarantee is made nor is any liability implied in regards to the accuracy of any descriptions, specifications or dimensions shown in this catalog.
- ~ Drawings in this catalog are NOT to scale and are for reference only.
- ~ Prices, specifications, and dimensions are subject to change without prior notice.
- ~ Quotations are valid for 30 days.
- ~ Quotations for **special order items** are good for **45 days**. **Special orders** will require a **non-refundable deposit** equal to **one-third** of the **Total Value** of the orders.

All sales are conducted with the understanding that the Buyer agrees to the above terms and conditions.



Galaxy Casters & Glides, Inc.

1860 South Carlos Avenue, Ontario, CA 91761

Tel : (909) 927-7455 Fax : (951) 228-9193

Application For Credit

For the purpose of obtaining merchandise from Galaxy Casters & Glides, Inc. (Seller), the following statement is made by the Applicant, intending that the Seller should rely on the same as correct.

BUSINESS Sole Proprietorship Partnership Corporation

NAME _____

ADDRESS _____

CITY _____ STATE _____ ZIP _____

() - () -

PHONE _____ FAX _____

Type of business: Cabinet Shop Office Furniture
 Government Other Woodworking
 Distributor Household Furniture

If for resale, provide
Resale Permit Number : _____

Federal Tax ID Number/
Social Security Number: _____

_____ \$ _____

YEARS IN BUSINESS CREDIT REQUESTED

OWNERSHIP List all owners, officers, or general partners (use a separate sheet if necessary).

NAME _____	TITLE _____	PHONE () - _____
STREET _____	CITY _____	STATE _____ ZIP _____
NAME _____	TITLE _____	PHONE () - _____
STREET _____	CITY _____	STATE _____ ZIP _____
NAME _____	TITLE _____	PHONE () - _____
STREET _____	CITY _____	STATE _____ ZIP _____

BANKING

NAME OF BANK _____ CHECKING ACCOUNT # _____

ADDRESS _____ SAVINGS ACCOUNT # _____

CITY _____ STATE _____ ZIP _____ PERSON TO CONTACT _____

() - () -

PHONE _____ FAX _____

TRADE REFERENCES

List only active vendors (4), no credit cards.

_____	()	—	()	—
VENDOR	PHONE		FAX	

STREET	CITY		STATE	ZIP
_____	()	—	()	—
VENDOR	PHONE		FAX	

STREET	CITY		STATE	ZIP
_____	()	—	()	—
VENDOR	PHONE		FAX	

STREET	CITY		STATE	ZIP
_____	()	—	()	—
VENDOR	PHONE		FAX	

STREET	CITY		STATE	ZIP

RELEASES

All three (3) sections of this "Release" MUST be signed.

The Applicant authorizes the use of a facsimile of this document as verification of release of information by reference to the Seller. Applicant agrees to pay for all merchandise purchased as per the standing terms stated in the "General Terms and Conditions of Sale" of the Seller. It is further understood that the Applicant will be responsible for any and all fees on any past due accounts. In the event of non-payment, the Applicant further agrees to assume all amounts due Seller by Applicant, including but not restricted to collection charges and/or attorney's fees.

Print Name and Title_____
Signature_____
Date_____
Print Name and Title_____
Signature_____
Date_____
Print Name and Title_____
Signature_____
Date

If a corporation, this document MUST be signed by an OFFICER. If a partnership, this document MUST be signed by ALL GENERAL PARTNERS.

PERSONAL GUARANTEE

In return for the extension of credit, the undersigned hereby jointly and severally guarantees to pay and be responsible for payment of all amounts due Seller by Applicant, including but not restricted to collection charges and/or attorney's fees. This shall be an open and continuing guarantee, notwithstanding changes, removal, extensions, or the like, granted by Seller. The undersigned hereby waives notice of default or non-payment. Seller shall be entitled to look to the undersigned for full payment without prior demand, notice or seeking recourse against any other party.

Print Name and Title_____
Signature_____
Date**BANK RELEASE**

I hereby authorize my bank, _____, to release any and all pertinent information to Galaxy Casters & Glides, Inc. For the purpose of establishing my credit with their company.

Company Name_____
Signature_____
Date

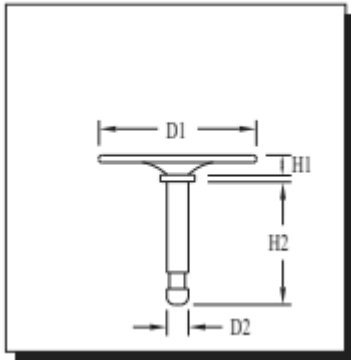
PLATE Type Stem

CODE NUMBER	D1	H1	D2	H2
#ST-01-2424	1-1/2" x 1-1/2"	3/16"	5/16"	1-3/16"
#ST-01-3219	2" x 1-3/16"	3/16"	5/16"	1-3/16"

MAT'L : STEEL
 FINISH : ZINC
 PACK : 500 pcs / ctn

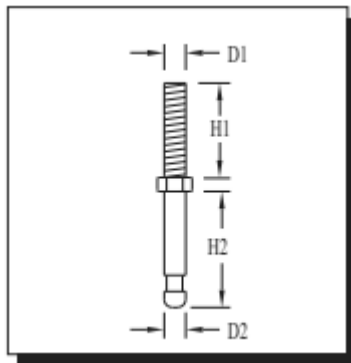
THREAD Type Stem

CODE NUMBER	D1	H1	D2	H2
#ST-02-412	1/4"- 20 Thread	3/4"	5/16"	1-3/16"
#ST-02-5xx	5/16"- 18 Thread	1/2", 3/4", 1", 1-1/2"	5/16"	1-3/16"
#ST-02-6xx	3/8"- 16 Thread	1"	5/16"	1-3/16"

MAT'L : STEEL
 FINISH : ZINC
 PACK : 500 pcs / ctn

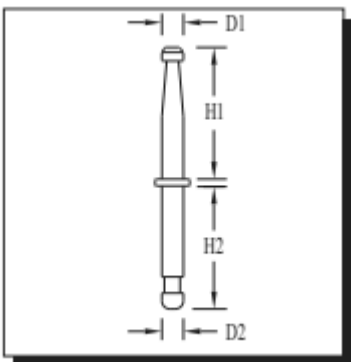
SOCKET Type Stem

CODE NUMBER	D1	H1	D2	H2
#ST-03-524	5/16"	1-1/2"	5/16"	1-3/16"

MAT'L : STEEL
 FINISH : ZINC
 PACK : 500 pcs / ctn

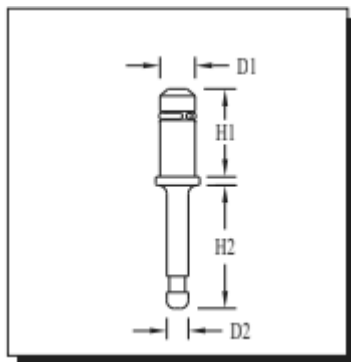
GRIP RING Type Stem

CODE NUMBER	D1	H1	D2	H2
#ST-04-714	7/16"	7/8"	5/16"	1-3/16"
#ST-04-724	7/16"	1-1/2"	5/16"	1-3/16"
#ST04-724B*	7/16"	1-1/2"	5/16"	1-3/16"

MAT'L : STEEL
 FINISH : ZINC / *BRASS RING (only)
 PACK : 500 pcs / ctn

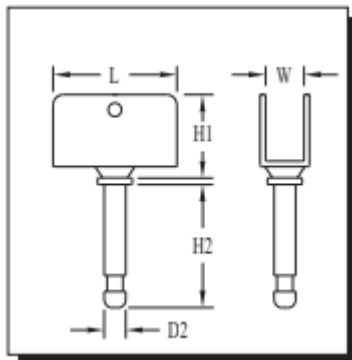

5/8" U-BRACKET Type Stem

CODE NUMBER	L x W	D2	H1	H2
#ST-05-10	1-9/16" x 5/8"	5/16"	1-7/16"	1-3/16"

MAT'L : STEEL
 FINISH : BLACK
 PACK : 250 pcs / ctn

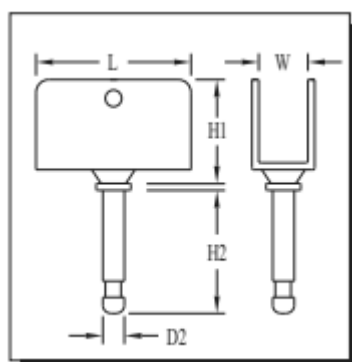

3/4" U-BRACKET Type Stem

CODE NUMBER	L x W	D2	H1	H2
#ST-05-12	1-9/16" x 3/4"	5/16"	1-9/16"	1-3/16"

MAT'L : STEEL
 FINISH : BLACK
 PACK : 200 pcs / ctn

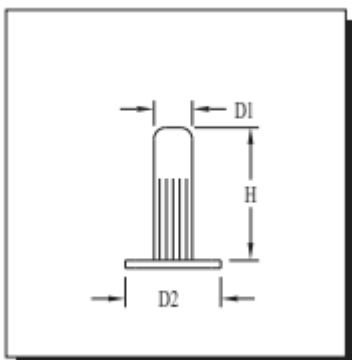

PLASTIC SOCKET

CODE NUMBER	D1	D2	H
#PCS-100	7/16"	15/16"	1-11/16"
#PCS-100-S	3/8"	5/8"	1-1/4"
#PCS-110xx	7/16"	3/4"	1-5/8"
#PCS-100-18-BL	7/8"	1" SQ	1-1/2"

MAT'L : NYLON / P.E. COLOR : BROWN / BLACK
 PACK : 5,000 pcs / ctn

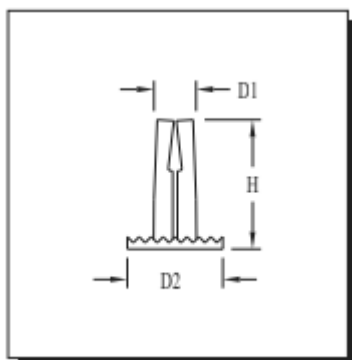

METAL SOCKET

CODE NUMBER	D1	D2	H
#MCS-100	5/16"	3/4"	1-1/4"

MAT'L : STEEL
 FINISH : ZINC / YELLOW ZINC
 PACK : 500 pcs / ctn

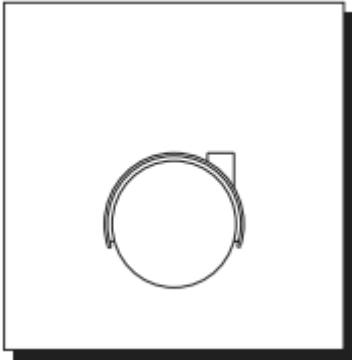

BODY w/o BRAKE

CODE NUMBER DESCRIPTION

#CN-400BL BLACK Wheel, BLACK Hood

MAT'L : NYLON
PACK : 200 pcs / ctn



BODY w/ BRAKE

CODE NUMBER DESCRIPTION

#CN-450BL BLACK Wheel, BLACK Hood

MAT'L : NYLON
PACK : 200 pcs / ctn



PLATE TYPE

CODE NUMBER DESCRIPTION

#CN-401BL-xxxx BLACK Wheel, BLACK Hood

NOTE : Available with BRAKE BODY (#CN-451BL-xxxx)
MAT'L : NYLON
PACK : 200 pcs / ctn



THREAD TYPE

CODE NUMBER DESCRIPTION

#CN-402BL-xxxx BLACK Wheel, BLACK Hood

NOTE : Available with BRAKE BODY (#CN-452BL-xxxx)
MAT'L : NYLON
PACK : 200 pcs / ctn

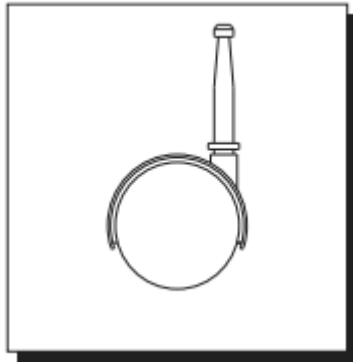

SOCKET TYPE

CODE NUMBER	DESCRIPTION
-------------	-------------

#CN-403BL-0524	BLACK Wheel, BLACK Hood
----------------	-------------------------

NOTE : Available with BRAKE BODY (#CN-453BL-0524)
 MAT'L : NYLON
 PACK : 200 pcs / ctn

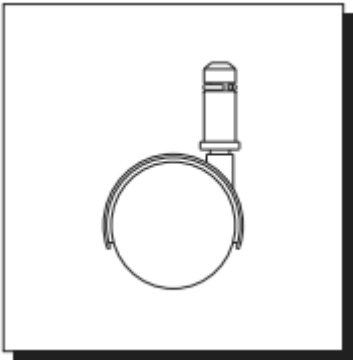

GRIP RING TYPE

CODE NUMBER	DESCRIPTION
-------------	-------------

#CN-404BL-xxxx	BLACK Wheel, BLACK Hood
----------------	-------------------------

NOTE : Available with BRAKE BODY (#CN-454BL-xxxx)
 MAT'L : NYLON
 PACK : 200 pcs / ctn



5/8" U-BRACKET TYPE

CODE NUMBER	DESCRIPTION
-------------	-------------

#CN-405BL-10	BLACK Wheel, BLACK Hood
--------------	-------------------------

NOTE : Available with BRAKE BODY (#CN-455BL-10)
 MAT'L : NYLON
 PACK : 200 pcs / ctn

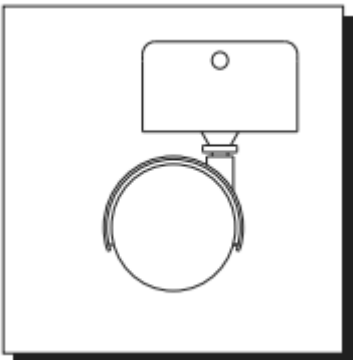

3/4" U-BRACKET TYPE

CODE NUMBER	DESCRIPTION
-------------	-------------

#CN-405BL-12	BLACK Wheel, BLACK Hood
--------------	-------------------------

NOTE : Available with BRAKE BODY (#CN-455BL-12)
 MAT'L : NYLON
 PACK : 200 pcs / ctn



50mm Twin Wheel Nylon

CASTERS

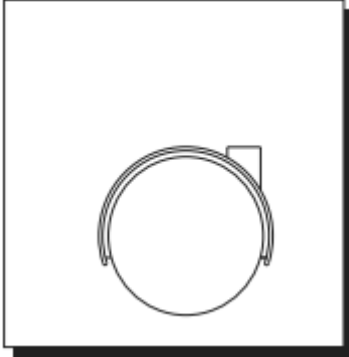

BODY w/o BRAKE

CODE NUMBER	DESCRIPTION
#CN-500BL*	BLACK Wheel, BLACK Hood
#CN-500CAT	BLACK Wheel, Antique Brass Metal Clip-On Hood
#CN-500CBT	BLACK Wheel, Brass Plated Metal Clip-On Hood
#CN-500CCT	BLACK Wheel, Chrome Metal Clip-On Hood
#CPU-500BL	BLACK POLYURETHANE Wheel, BLACK Hood

MAT'L : NYLON PACK : *200 pcs / ctn, 100 pcs / ctn

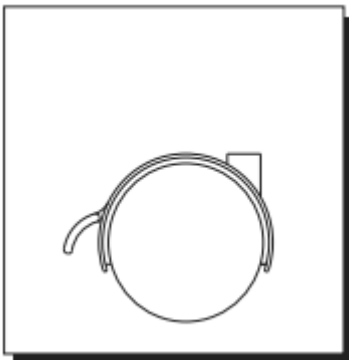

BODY w/ BRAKE

CODE NUMBER	DESCRIPTION
#CN-550BL*	BLACK Wheel, BLACK Hood w/ BRAKE
#CN-550CCT	BLACK Wheel, CHROME Plated Clip-On Hood w/ BRAKE
#CPU-550BL	BLACK POLYURETHANE Wheel, BLACK Hood

MAT'L : NYLON
PACK : *200 pcs / ctn, 100 pcs / ctn

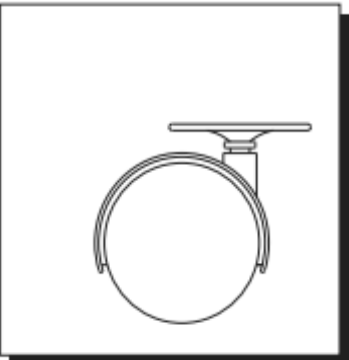
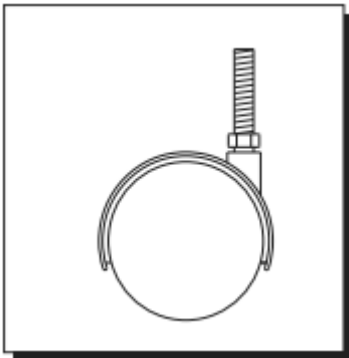

PLATE TYPE

CODE NUMBER	DESCRIPTION
#CN-501BL*	BLACK Wheel, BLACK Hood
#CN-501CAT	BLACK Wheel, Antique Brass Metal Clip-On Hood
#CN-501CBT	BLACK Wheel, Brass Plated Metal Clip-On Hood
#CN-501CCT	BLACK Wheel, Chrome Metal Clip-On Hood
#CPU-501BL	BLACK POLYURETHANE Wheel, BLACK Hood

MAT'L : NYLON NOTE: Available with BRAKE body
PACK : *200 pcs / ctn, 100 pcs / ctn



THREADED TYPE

CODE NUMBER	DESCRIPTION
#CN-502BL*	BLACK Wheel, BLACK Hood
#CN-502CAT	BLACK Wheel, Antique Brass Metal Clip-On Hood
#CN-502CBT	BLACK Wheel, Brass Plated Metal Clip-On Hood
#CN-502CCT	BLACK Wheel, Chrome Metal Clip-On Hood
#CPU-502BL	BLACK POLYURETHANE Wheel, BLACK Hood

MAT'L : NYLON NOTE: Available with BRAKE body
PACK : *200 pcs / ctn, 100 pcs / ctn

1860 South Carlos Avenue, Ontario, CA 91761
Tel : (909) 927-7455 Fax : (951) 228-9193

1.05

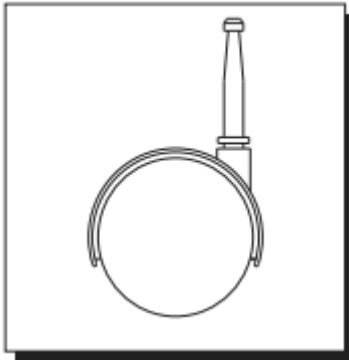

SOCKET TYPE

CODE NUMBER	DESCRIPTION
#CN-503BL-xxxx *	BLACK Wheel, BLACK Hood
#CN-503CAT	BLACK Wheel, Antique Brass Finished Metal Clip-On Hood
#CN-503CBT	BLACK Wheel, Brass Plated Finished Metal Clip-On Hood
#CPU-503BL-xxxx	BLACK POLYURETHANE Wheel, BLACK Hood

NOTE: Available with BRAKE body (#CN-553BL-xxxx)
 MAT'L : NYLON PACK : *200 pcs / ctn, 100 pcs / ctn

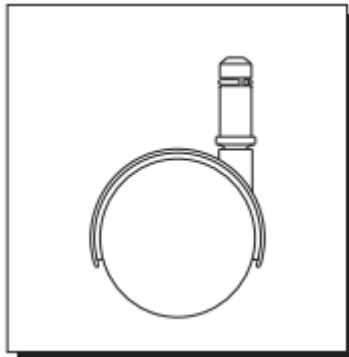

GRIP RING TYPE

CODE NUMBER	DESCRIPTION
#CN-504BL-xxxx *	BLACK Wheel, BLACK Hood
#CN-504CAT	BLACK Wheel, Antique Brass Finished Metal Clip-On Hood
#CN-504CBT	BLACK Wheel, Brass Plated Finished Metal Clip-On Hood
#CPU-504BL-xxxx	BLACK POLYURETHANE Wheel, BLACK Hood

NOTE: Available with BRAKE body (#CN-554BL-xxxx)
 MAT'L : NYLON PACK : *200 pcs / ctn, 100 pcs / ctn

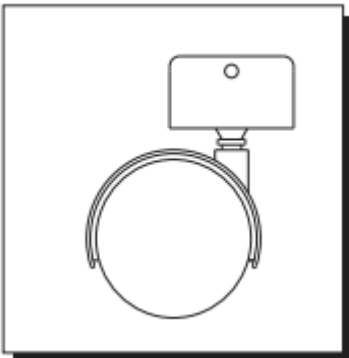

5/8" U-BRACKET TYPE

CODE NUMBER	DESCRIPTION
#CN-505BL-10	BLACK Wheel, BLACK Hood
#CPU-505BL-10	BLACK POLYURETHANE Wheel, BLACK Hood

NOTE: Available with BRAKE body (#CN-555BL-10)
 MAT'L : NYLON
 PACK : 100 pcs / ctn

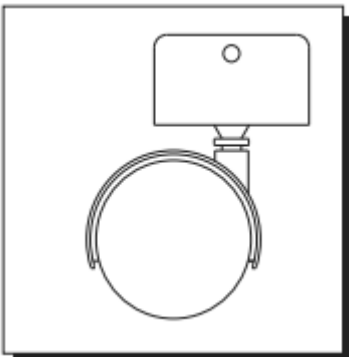

3/4" U-BRACKET TYPE

CODE NUMBER	DESCRIPTION
#CN-505BL-12	BLACK Wheel, BLACK Hood

NOTE: Available with BRAKE body (#CN-555BL-12)
 MAT'L : NYLON
 PACK : 100 pcs / ctn

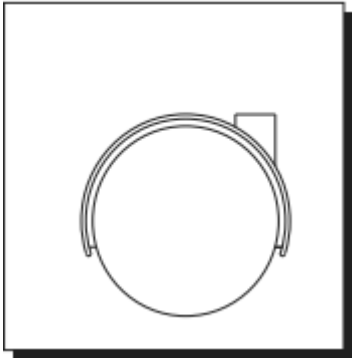

BODY w/o BRAKE

CODE NUMBER	DESCRIPTION
#CN-600BL	BLACK Wheel, BLACK Hood

MAT'L : NYLON
PACK : 100 pcs / ctn

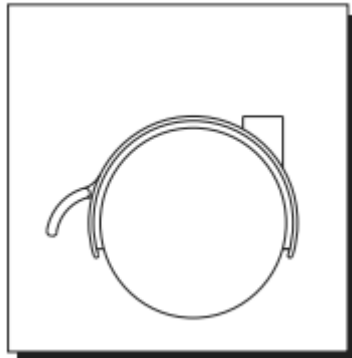

BODY w/ BRAKE

CODE NUMBER	DESCRIPTION
#CN-650BL	BLACK Wheel, BLACK Hood w/ BRAKE

MAT'L : NYLON
PACK : 100 pcs / ctn

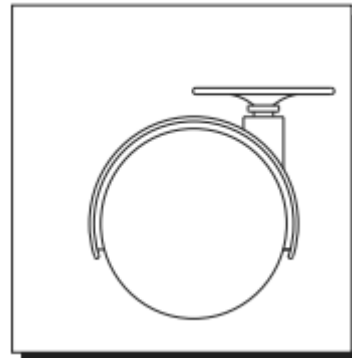
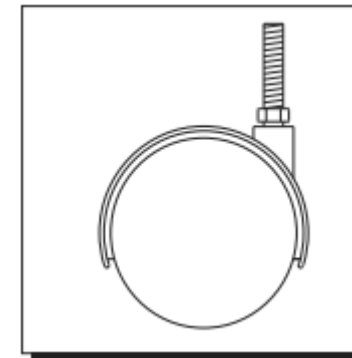

PLATE TYPE

CODE NUMBER	DESCRIPTION
#CN-601BL-xxxx	BLACK Wheel, BLACK Hood

NOTE: Available with BRAKE body (#CN-651BL-xxxx)
MAT'L : NYLON
PACK : 100 pcs / ctn



THREADED TYPE

CODE NUMBER	DESCRIPTION
#CN-602BL-xxxx	BLACK Wheel, BLACK Hood

NOTE: Available with BRAKE body (#CN-652BL-xxxx)
MAT'L : NYLON
PACK : 100 pcs / ctn



CASTERS

60mm Twin Wheel Nylon

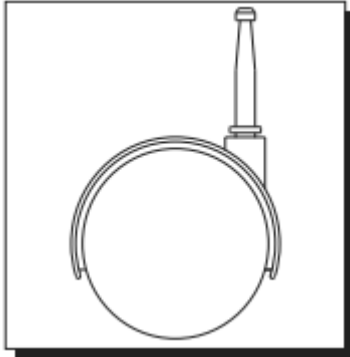

SOCKET TYPE

CODE NUMBER	DESCRIPTION
#CN-603BL-xxxx	BLACK Wheel, BLACK Hood

NOTE: Available with BRAKE body (#CN-653BL-xxxx)
MAT'L : NYLON
PACK : 100 pcs / ctn

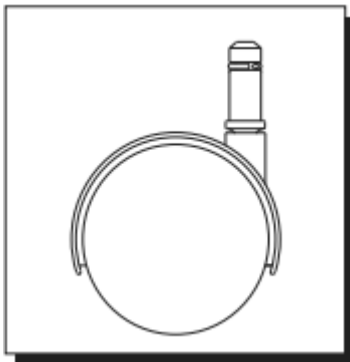

GRIP RING TYPE

CODE NUMBER	DESCRIPTION
#CN-604BL-xxxx	BLACK Wheel, BLACK Hood

NOTE: Available with BRAKE body (#CN-654BL-xxxx)
MAT'L : NYLON
PACK : 100 pcs / ctn

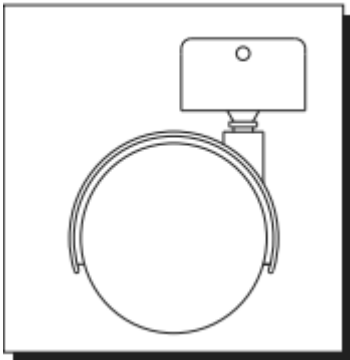

5/8" U-BRACKET TYPE

CODE NUMBER	DESCRIPTION
#CN-605BL-10	BLACK Wheel, BLACK Hood

NOTE: Available with BRAKE body (#CN-655BL-10)
MAT'L : NYLON
PACK : 100 pcs / ctn

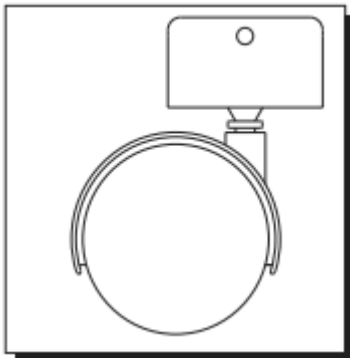

3/4" U-BRACKET TYPE

CODE NUMBER	DESCRIPTION
#CN-605BL-12	BLACK Wheel, BLACK Hood

NOTE: Available with BRAKE body (#CN-655BL-12)
MAT'L : NYLON
PACK : 100 pcs / ctn

1.08

1860 South Carlos Avenue, Ontario, CA 91761
Tel : (909) 927-7455 Fax : (951) 228-9193



GLIDES / LEVELERS

CUSHION NAIL ON GLIDES

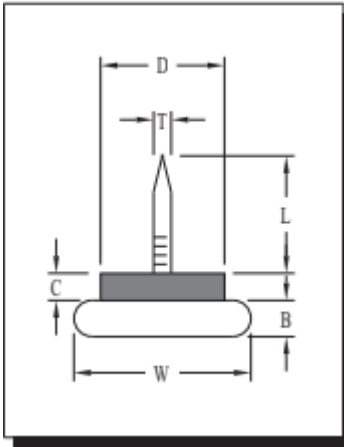

CODE NUMBER	W	B	D	C	T x L
#GX-1278-0	3/4"	3/16"	9/16"	3/16"	2.6 mm x 3/4"
#GX-1278-1	7/8"	1/4"	3/4"	1/4"	2.6 mm x 3/4"
#GX-1278-1S	7/8"	1/4"	3/4"	1/4"	2.1 mm x 3/4"
#GX-1278-1L	7/8"	1/4"	3/4"	1/4"	2.6 mm x 1-1/8"
#GX-1278-2	1- 1/16"	1/4"	3/4"	1/4"	2.6 mm x 3/4"

FINISH : BLACK Soft Plastic Cushion with N/P Steel Shell

PACK : 2,000 pcs / ctn

CUSHION ADJUSTABLE LEVELERS

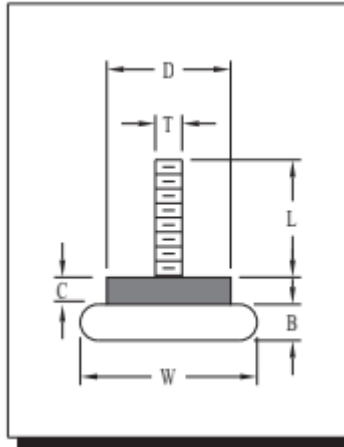

CODE NUMBER	W	B	D	C	T x L
#GX-1279-10	7/8"	1/4"	3/4"	1/4"	1/4" - 20 x 1"
#GX-1279-11	7/8"	1/4"	3/4"	1/4"	5/16" - 18 x 1"
#GX-1279-21	1-1/16"	1/4"	3/4"	1/4"	5/16" - 18 x 1"

FINISH : BLACK Soft Plastic Cushion with N/P Steel Shell

PACK : 1,000 pcs / ctn

MONACO ADJUSTABLE LEVELER

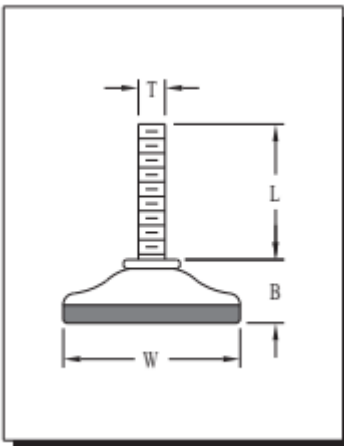

CODE NUMBER	W	B	T x L
#GX-1293	1-1/8"	3/8"	1/4" - 20 x 1", 1/2"
#GX-1294	1-1/8"	3/8"	5/16" - 18 x 1", 1/2"
#GX-1294-38	1-1/8"	3/8"	3/8" - 16 x 1"
#GX-1297	1-11/16"	7/16"	5/16" - 18 x 1"

FINISH : WHITE / BLACK Plastic Base with N/P Steel Shell

PACK : 1,000 pcs / ctn

GLIDES / LEVELERS

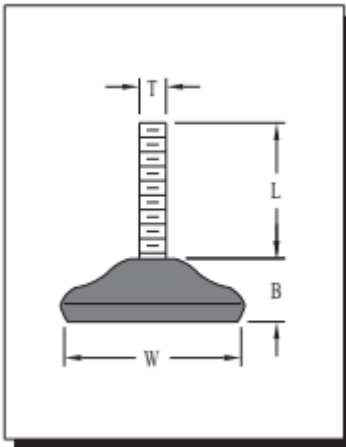

MONTANA ADJUST. LEVELER

CODE NUMBER	W	B	T x L
#GX-1483xx	1-1/8"	5/16"	1/4" - 20 x 1"
#GX-1484xx	1-1/8"	5/16"	5/16" - 18 x 1"

FINISH : BLACK / DARK BROWN Plastic Base, No Shell
 PACK : 1,000 pct / ctn

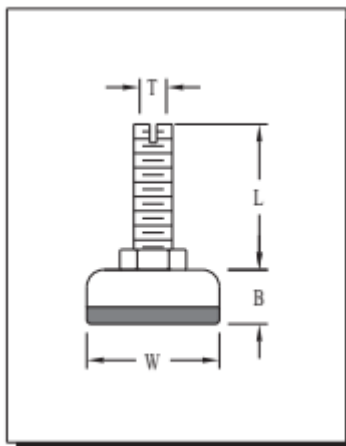

HEAVY DUTY ADJUST. LEVELER

CODE NUMBER	W	B	T x L
#GX-1285-2*	1-3/8"	9/16"	3/8" - 16 x 1-3/4"
#GX-1285-23 **	1-3/8"	9/16"	3/8" - 16 x 3-1/4"

FINISH : WHITE Plastic Base with N/P Steel Shell
 PACK : *400 pcs / ctn
 **200 pcs / ctn

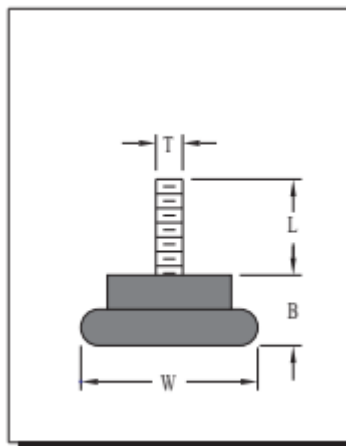

TANGO FLOOR GLIDE

CODE NUMBER	W	B	T x L
#GX-1600-0	7/8"	7/16"	1/4" - 20 x 1/2"
#GX-1600-1	7/8"	7/16"	5/16" - 18 x 7/8"
#GX-1600-2	1"	7/16"	5/16" - 18 x 1-1/2"

COLOR : BLACK / BROWN Plastic Base, Zinc Plated Stems
 PACK : 2,000 pcs / ctn

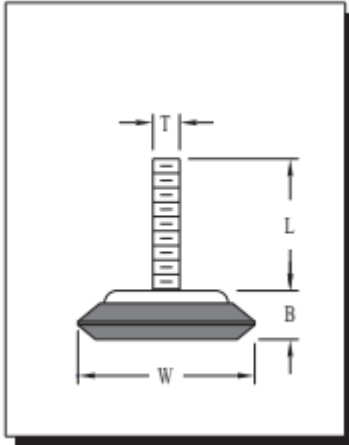

NON-SKID AJDUST. LEVELER

CODE NUMBER	W	B	T x L
#GX-1700-0 *	1-1/8"	7/16"	1/4" - 20 x 7/8"
#GX-1700-1 **	1-1/8"	7/16"	5/16 - 18 x 1"

COLOR : BLACK
 PACK : * 2,000 pcs /ctn
 ** 1,500 pcs / ctn

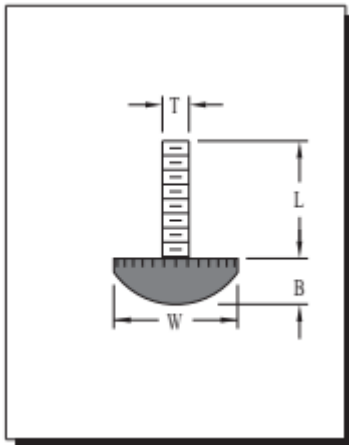

OVAL HEAD ADJUST. FLOOR GLIDE

CODE NUMBER	W	B	T x L
#GX-1262	3/4"	1/4"	1/4" - 20 x 1"
#GX-1263	7/8"	1/4"	1/4" - 20 x 1"

FINISH: BROWN / TAN Plastic Base, Z/P Threaded Stems
 PACK : 2,000 pcs /ctn

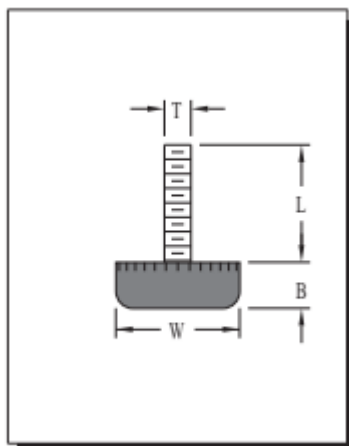

FLAT HEAD ADJUST. FLOOR GLIDE

CODE NUMBER	W	B	T x L
#GX-1272	3/4"	1/4"	1/4" - 20 x 1"
#GX-1273	7/8"	1/4"	1/4" - 20 x 1"
#GX-1275	1-1/8"	1/4"	1/4" - 20 x 1"

FINISH: BROWN / TAN Plastic Base, Z/P Threaded Stems
 PACK : 2,000 pcs /ctn

SINGLE PRONG METAL GLIDES

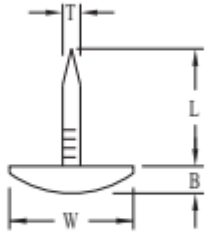

CODE NUMBER	W	B	T x L
#GM-1312-NP	3/4"	1/8"	2.1 mm x 5/8"

FINISH: PLAIN STEEL, LACQUERED
 PACK : 5,000 pcs /ctn

ROUND OVAL TACK GLIDE

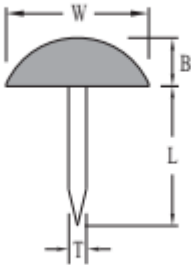

CODE NUMBER	W	B	T x L
#GP-1213	5/8"	3/16"	1.8 mm x 11/16"
#GP-1214	3/4"	3/16"	1.8 mm x 11/16"

COLOR: BROWN / TAN Plastic Base, Z/P Nail
 PACK : 10,000 pcs /ctn

ROUND FLAT TACK GLIDE

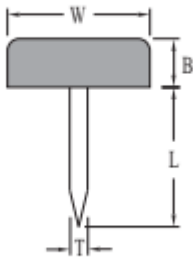

CODE NUMBER	W	B	T x L
#GP-1216	5/8"	1/4"	1.8 mm x 5/8"
#GP-1218	3/4"	1/4"	1.8 mm x 5/8"
#GP-1220	7/8"	1/4"	1.8 mm x 5/8"
#GP-1220-L	7/8"	1/4"	2.6 mm x 1-1/4"

COLOR: BROWN, WHITE Plastic Base, Z/P Nail
 PACK : 5,000 pcs /ctn

ROUND FLAT TACK GLIDE

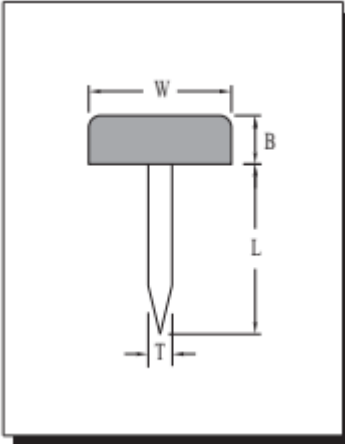

CODE NUMBER	W	B	T x L
#GP-1222 *	1"	1/4"	1.8 mm x 5/8"
#GP-1222-L	1"	1/4"	2.6 mm x 1-1/4"
#GP-1224	1-1/8"	1/4"	1.8 mm x 11/16"

COLOR: WHITE Plastic Base, Z/P Nail
 PACK : * 5,000 pcs / ctn

CUSHION NAIL ON GLIDE

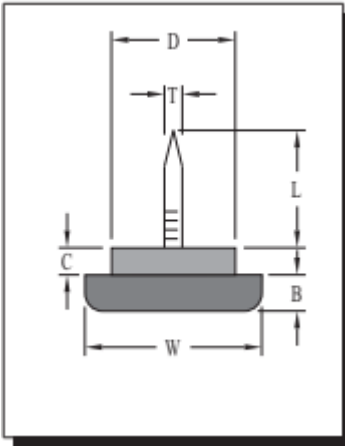

CODE NUMBER	W	B	D	C	T x L
#GP-1229-L	7/8"	1/4"	3/4"	1/8"	2.6 mm x 1-1/16"
#GP-1230-L	1"	1/4"	3/4"	1/8"	2.6 mm x 1-1/16"
#GP-1231-L	1-1/8"	1/4"	3/4"	1/8"	2.6 mm x 1-1/16"

COLOR: WHITE Plastic Base, BLACK Soft Plastic Cushion Z/P Nail
 PACK : 5,000 pcs / ctn

SPECIAL NOTE: Tolerance of all dimensions is +/- 1/16".

All dimensions are for reference only and are subject to change without notice.

We welcome all inquiries and custom designs.

New products are available upon special arrangement.

This page intentionally left blank



ABS / PLASTIC

HANDLES

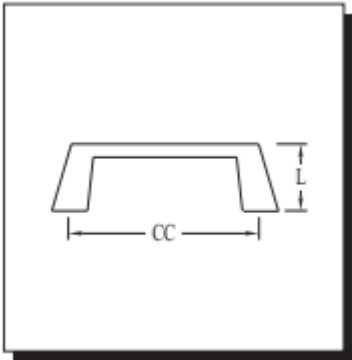

ABS / PLASTIC PULL

CODE NUMBER	CC	L
#HP-05008-100	4"	1"

COLOR : BLACK, CHROME Plated
 PACK : 1,000 pcs / ctn

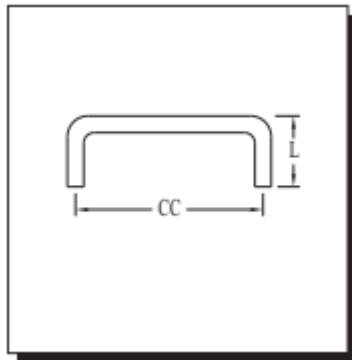

3/8" DIA. PLASTIC WIRE PULL

CODE NUMBER	CC	L
#HP-05009-75	3"	1-3/8"
#HP-05009-96	96 mm	1-3/8"

COLOR : VARIOUS, CALL FOR AVAILABILITY
 PACK : 1,000 pcs / ctn

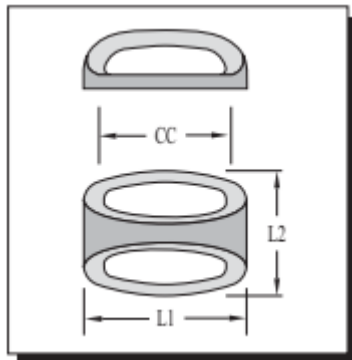

ABS / PLASTIC PULL

CODE NUMBER	CC	L1	L2
#F-102-G	2-1/2"	3-3/16"	2-5/16"

COLOR : GOLD
 PACK : 500 pcs / ctn

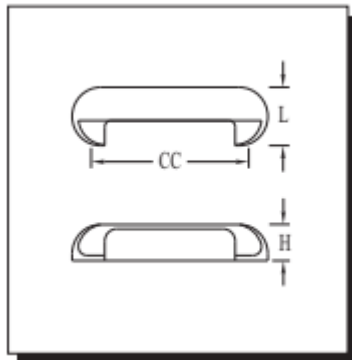

ABS / PLASTIC HANDLE

CODE NUMBER	CC	L x H
#F-104-96	96 mm	1-7/16" x 13/16"

COLOR : BLACK, DARK GREY, TAUPE
 PACK : 500 pcs / ctn



ZINC DIE CAST

HANDLES

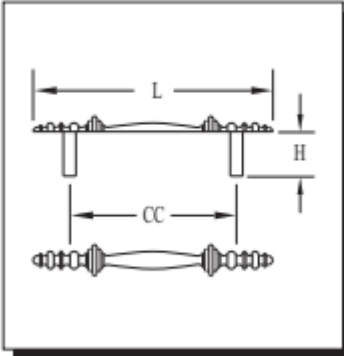

DRAWER PULL

CODE NUMBER	CC	L	H
#ZD-26086-0	3"	4-3/8"	9/16"

FINISH : A/B
PACK : 1,000 pcs / ctn

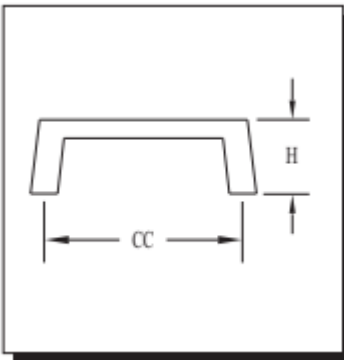

ZINC DIE CAST PULL

CODE NUMBER	CC	H
#HP-05007-100	4"	7/8"

FINISH : CHROME Plated
PACK : 500 pcs / ctn

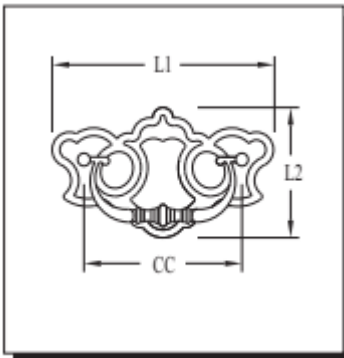

BAIL PULL

CODE NUMBER	CC	L1	L2
#ZD-26140-1	3"	3-7/8"	2"

FINISH : B/P
PACK : 500 pcs / ctn

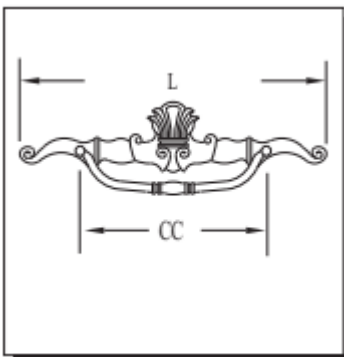

RIGID PULL

CODE NUMBER	CC	L
#ZD-26124-0	5"	6-7/8"

FINISH : A/E
PACK : 500 pcs / ctn

3.02

1860 South Carlos Avenue, Ontario, CA 91761
Tel : (909) 927-7455 Fax : (951) 228-9193

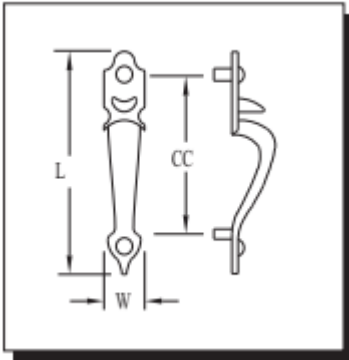

DOOR / DRAWER PULL

CODE NUMBER	CC	L
#ZD-71540-0	3-1/2"	6-7/8"

FINISH : A/E
PACK : 500 pcs / ctn

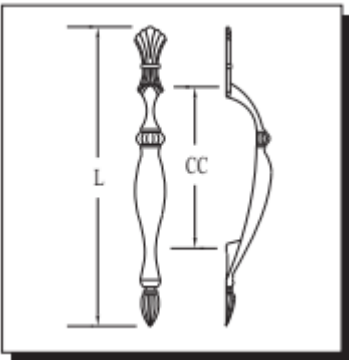

DOOR / DRAWER PULL

CODE NUMBER	CC	L
#ZD-26006-0	3"	5-3/4"

FINISH : A/E
PACK : 500 pcs / ctn

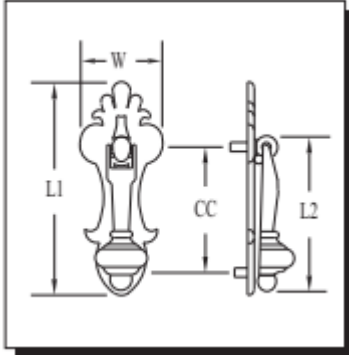

BAIL PULL

CODE NUMBER	L1	L2	W	CC
#ZD-26144-0	4"	2-11/16"	1-3/4"	2"

FINISH : A/E
PACK : 500 pcs / ctn

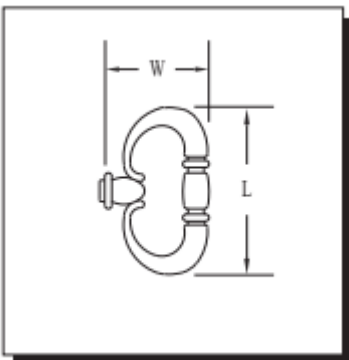

D RING

CODE NUMBER	L	W
#ZD-46012-0	1-1/4"	1"

FINISH : A/E
PACK : 1,000 pcs / ctn

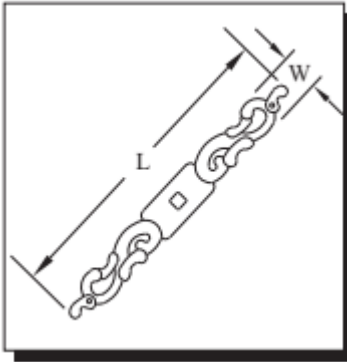

BACK PLATE

CODE NUMBER	L	W
#ZD-66014-0	5-3/16"	3/4"

FINISH : A/E
 PACK : 1,000 pcs / ctn

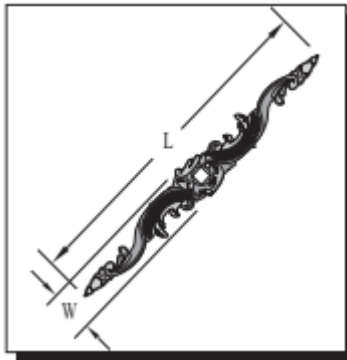

BACK PLATE

CODE NUMBER	L	W
#HZ-66118-XAA	6-1/8"	3/4"

FINISH : A/E
 PACK : 1,000 pcs / ctn

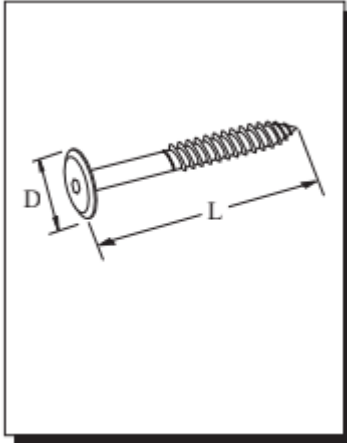

(CW TYPE) RTA SCREW

CODE NUMBER	L	D	THREAD
#BS-33012-740*	40 mm	13 mm	7.3 mm
#BS-33012-750**	50 mm	13 mm	7.5 mm
#BS-33012-770***	70 mm	13 mm	7.5 mm
#BS-33012-780****	80 mm	13 mm	7.5 mm

FINISH : A/C STEEL

PACK : *2,500 pcs / ctn, **2,000 pcs / ctn, ***1,500 pcs / ctn, ****1,100 pcs / ctn

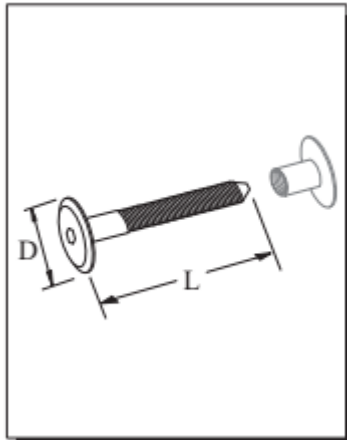

(BB/BC TYPE) RTA SCREW

CODE NUMBER	L	D	THREAD
#BS-33023-650	50 mm	13 mm	M 6
#BS-33023-1450	50 mm	13 mm	1/4" - 20

FINISH : A/C STEEL

PACK : 1,000 pcs / ctn

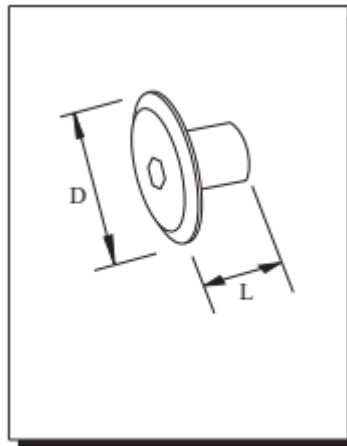

JCN TYPE CONNECTOR

CODE NUMBER	L	D	THREAD
#NS-55031-612	12 mm	13 mm	M 6
#NS-55031-1412	12 mm	17 mm	1/4" - 20

FINISH : A/C STEEL

PACK : 5,000 pcs / ctn

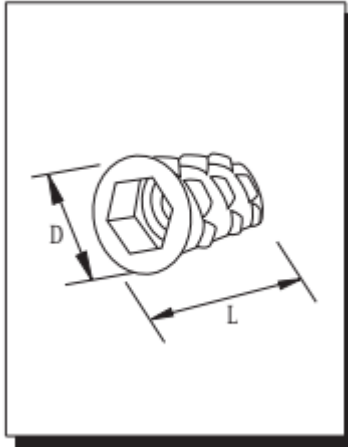

D-NUT

CODE NUMBER	D	L	THREAD
#NS-55034-620	12.5 mm	20 mm	M 6
#NS-55034-1413	12.5 mm	13 mm	1/4" - 20
#NS-55034-1420	12.5 mm	20 mm	1/4" - 20
#NS-55034-5613	14.5 mm	13 mm	5/16" - 18

FINISH : Z/P
PACK : 2,000 pcs /ctn

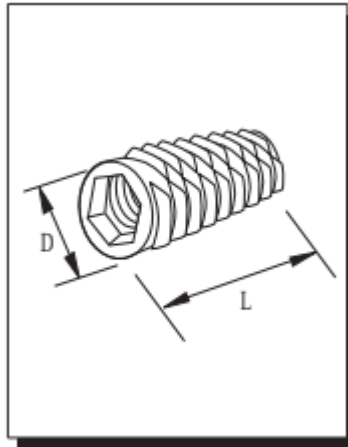

E-NUT

CODE NUMBER	D	L	THREAD
#NS-55035-620	12 mm	20 mm	M 6
#NS-55035-1413	12 mm	13 mm	1/4" - 20
#NS-55035-5613	14.5 mm	13 mm	5/16" - 18

FINISH : Z/P
PACK : 2,000 pcs /ctn



MAGNETIC

CATCHES

MAGNETIC CATCH

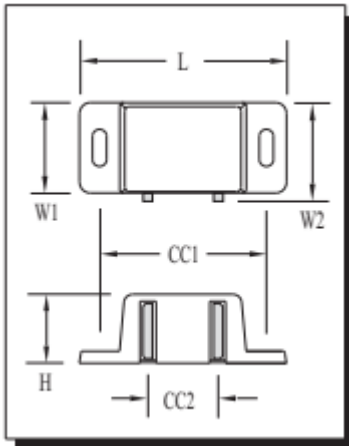

CODE NUMBER	L	W1	W2	CC1	CC2	H
#CP-54003	2"	3/4"	13/16"	1-1/2"	1/2"	9/16"

NOTE : Use #CP-54004-SP Strike Plates
 COLOR : BROWN
 PACK : 500 pcs /ctn

MAGNETIC CATCH

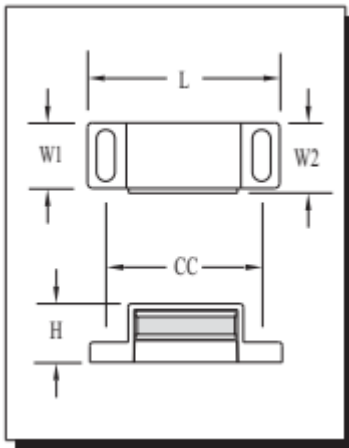

CODE NUMBER	L	W1	W2	CC	H
#CP-54004	1-13/16"	9/16"	5/8"	1-7/16"	1/2"

NOTE : Use #CP-54004-SP Strike Plates
 COLOR : DARK BROWN
 PACK : 1,000 pcs /ctn

MAGNETIC CATCH

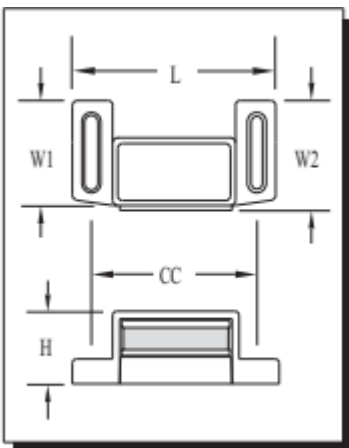

CODE NUMBER	L	W1	W2	CC	H
#CP-54005	1-15/16"	13/16"	7/8"	1-1/2"	9/16"

NOTE : Use #CP-54004-SP Strike Plates
 COLOR : DARK BROWN
 PACK : 1,000 pcs /ctn

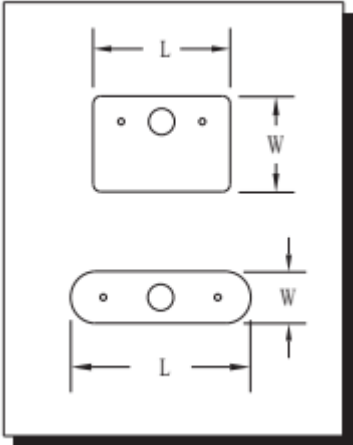

STRIKE PLATES

CODE NUMBER	L	W
#CP-54004-SPL	1"	7/8"
#CP-54004-SPS	1-3/8"	1/2"

NOTE : Can be used with MOST Magnetic Catches
 FINISH : Z/P or A/C
 PACK : 5,000 pcs /ctn

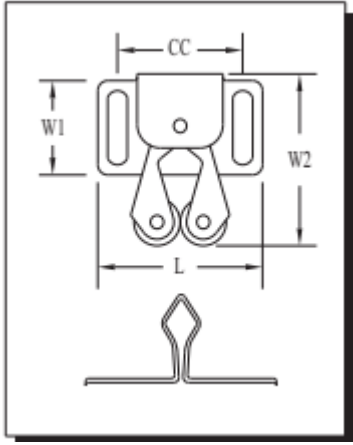

DOUBLE ROLLER CATCH

CODE NUMBER	L	W1	W2	CC
#CS-55432	1-1/4"	11/16"	1-1/8"	15/16"

FINISH : A/C
 PACK : 1,000 pcs /ctn

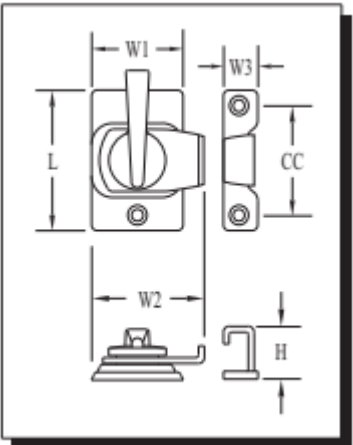

HEAVY DUTY SASH LOCK

CODE NUMBER	L	W1	W2	W3	CC	H
#WS-91153	2-3/16"	1-5/16"	1-5/8"	5/8"	1-5/8"	3/4"

MAT'L : STEEL
 FINISH : B/P OR YELLOW ZINC
 PACK : 200 sets / ctn



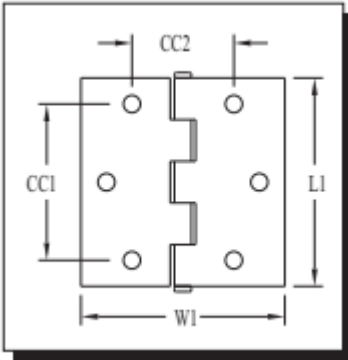

BUTT HINGE

CODE NUMBER	CC1	CC2	L1	W1
#HS-82005-BAA*	1-7/8"	1-5/16"	2-1/2"	2-1/2"
#HS-82005-AAA**	1-5/16"	7/8"	2"	1-1/2"

MAT'L : STEEL
 FINISH : A/B
 PACK : *480 pcs / ctn, **720 pcs / ctn

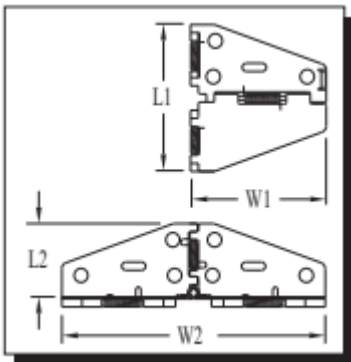
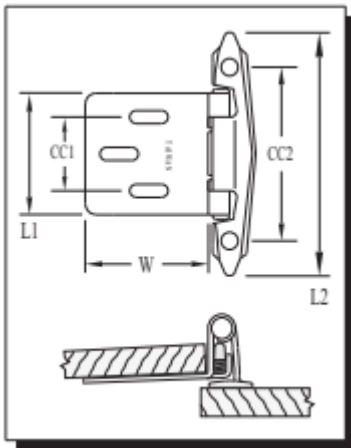

TABLE HINGE

CODE NUMBER	L1	L2	W1	W2
#HS-86015	5-1/8"	2-1/2"	4"	7-1/2"

MAT'L : STEEL
 FINISH : YELLOW ZINC
 PACK : 60 pcs / ctn



FLAT SELF-CLOSING HINGE

CODE NUMBER	L1	L2	W	CC1	CC2
#HS-82013-S	1-1/2"	2-3/4"	1-3/8"	7/8"	2-1/8"

MAT'L : STEEL
 FINISH : B/P
 PACK : 500 pcs / ctn

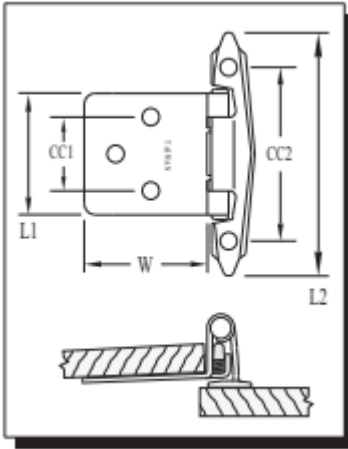

FLAT SELF-CLOSING HINGE

CODE NUMBER	L1	L2	W	CC1	CC2
#HS-82013	1-1/2"	2-3/4"	1-3/8"	7/8"	2-1/8"

MAT'L : STEEL
 FINISH : B/P
 PACK : 500 pcs / ctn

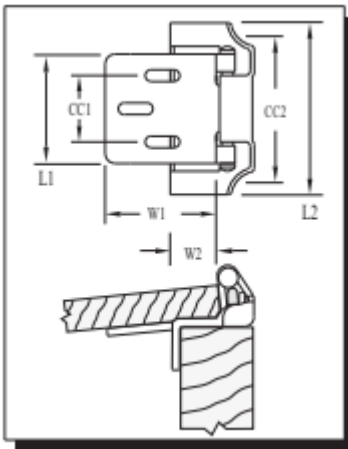

OVERLAY SELF-CLOSING HINGE

CODE NUMBER	L1	L2	W1	W2	CC1	CC2
#HS-82015-14	1-1/2"	2-1/4"	1-3/8"	1/4"	15/16"	1-1/2"
#HS-82015-12	1-1/2"	2-1/4"	1-3/8"	1/2"	15/16"	1-1/2"
#HS-82015-1232	1-1/2"	2-1/4"	1-3/8"	1/2"	15/16"	32 mm

MAT'L : STEEL
 FINISH : B/P, A/B
 PACK : 300 pcs / ctn

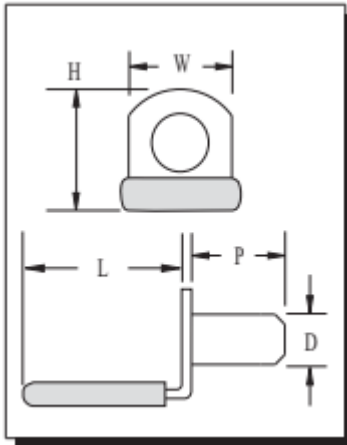

L - TYPE SHELF SUPPORT

CODE NUMBER	L	H	W	P	D
#SS-21191-C	3/4"	5/8"	1/2"	3/8"	1/4"
#SS-21191	3/4"	5/8"	1/2"	3/8"	1/4"

MAT'L : STEEL
 FINISH : B/P or A/B with BROWN PVC coating (image displayed) and without coating
 PACK : 2,500 pcs / ctn

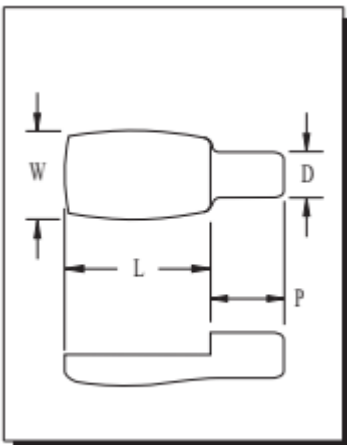

SPOON - TYPE SHELF SUPPORT

CODE NUMBER	L	W	P	D
#SS-21196-14*	1/2"	3/8"	3/8"	1/4"
#SS-21196-05**	3/8"	5/16"	5/16"	5 mm

MAT'L : STEEL
 FINISH : B/P or N/P
 PACK : *5,000 pcs / ctn,
 **10,000 pcs / ctn

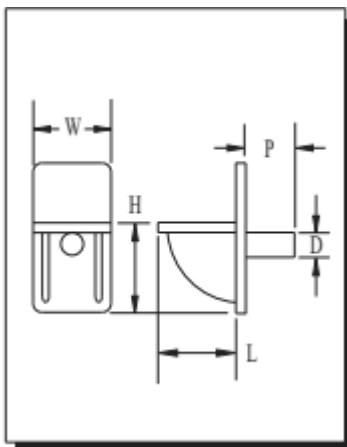

PLASTIC SHELF SUPPORT

CODE NUMBER	L	W	H	P	D
#SS-21197-LCB	1/2"	1/2"	5/8"	5/16"	5 mm

MAT'L : NYLON or P.E.
 COLOR : CHOCOLATE BROWN
 PACK : 5,000 pcs / ctn

SHELF SUPPORTS

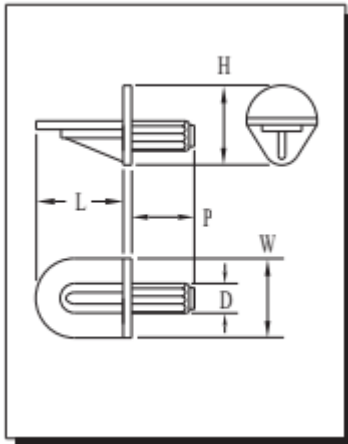

CLEAR SHELF SUPPORT

CODE NUMBER	L	W	H	P	D
#SP-21203-C	7/16"	1/2"	1/2"	13/16"	1/4"
#SP-21203-LC	1"	1/2"	1/2"	13/16"	1/4"

MAT'L : LEXAN, POLYCARBONATE
 COLOR : CLEAR
 PACK : 5,000 pcs / ctn

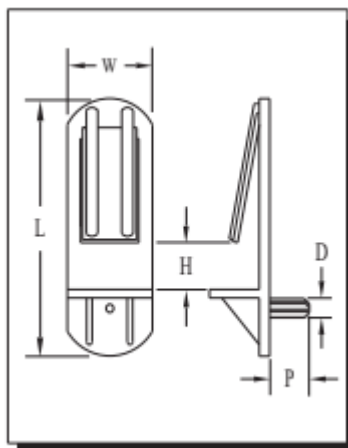

SELF-LOCKING SHELF SUPPORT

CODE NUMBER	L	W	H	P	D
#SP-21204	2-1/4"	3/4"	1/2"	5/16"	1/4"

MAT'L : P.E.
 COLOR : CHOCOLATE BROWN
 PACK : 1,000 pcs / ctn

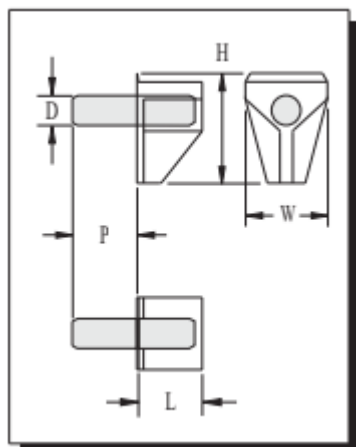

STEEL PIN SHELF SUPPORT

CODE NUMBER	L	W	H	P	D
#SP-21197-05C	3/8"	7/16"	19/32"	5/16"	5 mm
#SP-21197-14C	3/8"	7/16"	19/32"	3/8"	1/4"

MAT'L : LEXAN with STEEL Pin
 COLOR : CLEAR OR OPAQUE
 PACK : 5,000 pcs / ctn

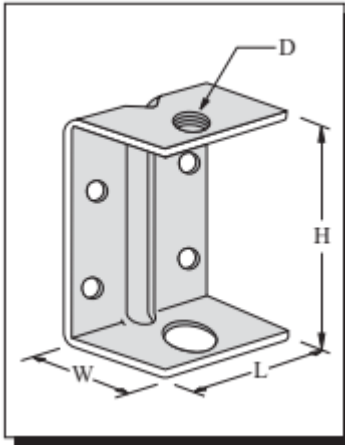

C - BRACKET

CODE NUMBER	L	W	H	D
#SBC-112038-NP	1-3/8"	1-1/8"	1-5/8"	3/8" - 16
#SBC-112516-NP	1-3/8"	1-1/8"	1-5/8"	5/16" - 18

MAT'L : N/P STEEL
 PACK : 250 pcs / ctn

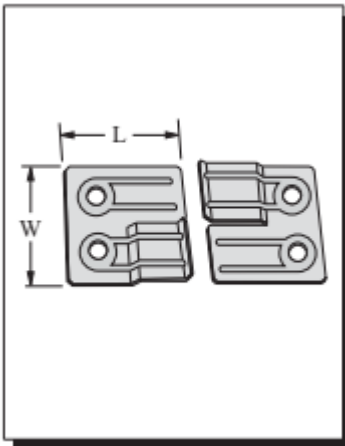

TABLE TOP LEVELER

CODE NUMBER	L	W	THK
#TTL-112-P	1-1/2"	1-1/2"	1.2 mm

MAT'L : PLAIN STEEL
 PACK : 1,000 pcs / ctn

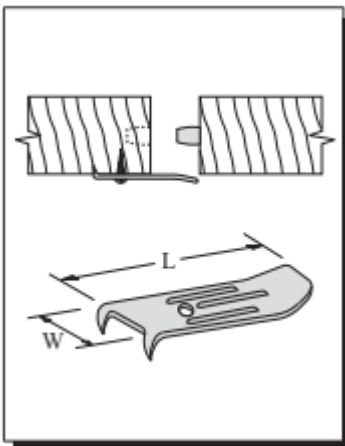
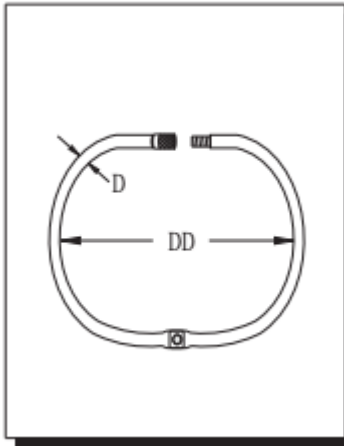

TABLE TOP EVENER

CODE NUMBER	L	W	THK
#TTE-58158-R*	1-5/8"	5/8"	1.2 mm
#TTE-34200-P**	2"	3/4"	1.2 mm

MAT'L : PLAIN STEEL
 PACK : *3,000 pcs / ctn,
 **2,000 pcs / ctn



UPHOLSTERY FABRIC RING

CODE NUMBER	D	DD
#WI-21200-3NX*	5 mm	3"
#WI-21200-4NX*	5 mm	4"
#WI-21200-5NX**	5 mm	5"
#WI-21200-6NX***	5 mm	6"
#WI-21200-8NX****	5.5 mm	8"
#WI-21200-10NX*****	5.5 mm	10"

MAT'L : N/P STEEL

PACK : *500 pcs / ctn, **400 pcs / ctn, ***300 pcs / ctn, ****200 pcs / ctn, *****100 pcs / ctn

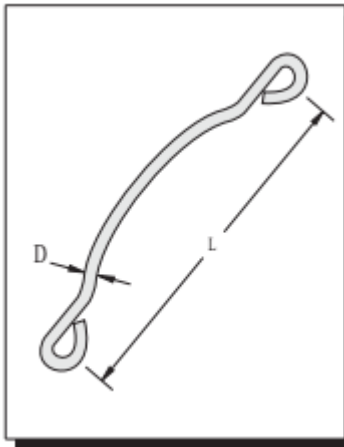

FABRIC RING HANDLE

CODE NUMBER	D	L
#WI-21201-9	1/4"	9"
#WI-21201-10	1/4"	10"

MAT'L : N/P STEEL

PACK : 200 pcs / ctn